



---

CONCERTINO COLLECTION

# *Trumpet*

---

INSTRUMENTS THAT OUTPERFORM

---

## Assembly, Care & Maintenance Guide



The Name You Know

[www.suzukibandinstruments.com](http://www.suzukibandinstruments.com)

# STOP!

## Read This First Before You Assemble Your Trumpet

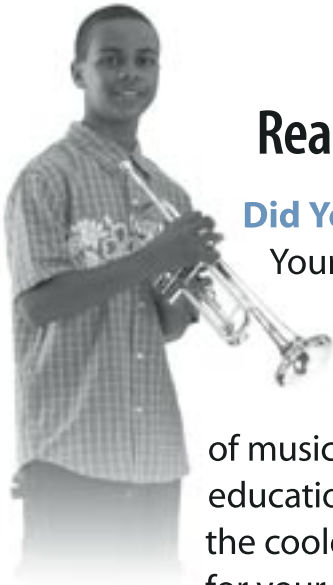

### Did You Know This?

Your new Trumpet is manufactured by the Suzuki Corporation, the Worlds largest producer of musical instruments for education. We have been making the coolest musical instruments for your school and church for

over 50 years! And now, we've designed a Trumpet that you can learn to play quickly and easily. We know you can't wait to play in the band, marching band or orchestra and make exciting music together with all your friends. Playing a musical instrument, especially in a group, is an incredible experience. If you pay attention and study a little each day, pretty soon you will be amazed at the awesome music you will be able to perform. And your Suzuki Trumpet will perform for you too. Together, you'll both have a really great time!

### This Is A Precise And Delicate Instrument . . . Be Careful With It!

The Trumpet, as with all musical instruments, is a precise, yet delicate instrument. It has many parts, all coming together to



create a beautiful musical instrument. You must be very careful when handling your new Trumpet, putting it together and taking it apart. We recommend that you let your music teacher show you how your new Trumpet should be assembled and dis-assembled. You'll get the hang of it very quickly. In the meantime, read through this brochure now so you can get familiar with the assembly and care of your new Trumpet. And be careful!

### Wanna Get Good On Your Instrument Real Fast?

Who is your favorite band or musician? Whether you like rock, pop, country or classical, you can be sure that all the best players had one thing in common . . . a private teacher. After your music teacher has shown you the basics of how to put your instrument together and how to play a few notes, its time to get some private instruction. Your music teacher may have some recommendations or may even be the perfect private teacher you are looking for. It's a great way to get real good, real fast.



**If You Have Any Problems Or Questions About Your Trumpet, Call Us Toll Free. We Can Help You.**

*Do Not Return Your Trumpet To The Store!*

# 1-800-854-1594

You can also visit our web site at [www.suzukibandinstruments.com](http://www.suzukibandinstruments.com)

## 1. UNPACKING YOUR NEW TRUMPET



### A. Position the Case

Place the aluminum "Roadie" Trumpet case in front of you as shown in this picture. You should be able to see the Suzuki logo on the case. If you do not see the logo, the case is upside down and should NOT be opened. Open the case ONLY if you can see this logo.



### B. Open the Case

Unhook the 2 latches on either side of the handle and open the lid. Your new Trumpet and Mouthpiece must be CAREFULLY unwrapped.



### C. Unwrap Your Trumpet

• Slowly remove the plastic covering and paper wrapping on the Trumpet and Mouthpiece.

*Carefully put the Trumpet and Mouthpiece back in the case in their proper compartments!*

## 2. HERE ARE THE NAMES OF YOUR TRUMPET PARTS

### A. Carrying Case

When you open the lid of your new Trumpet Carrying Case, you will see the Trumpet, Mouthpiece and Storage Compartment.

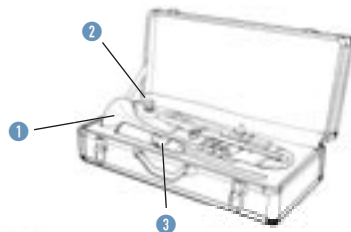

1. Trumpet
2. Mouthpiece
3. Storage Compartment

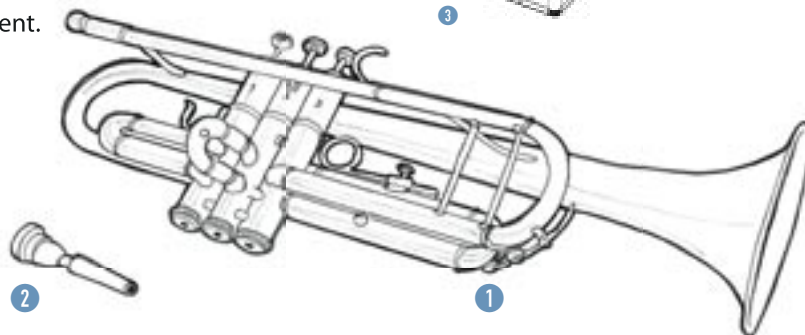

### B. Accessories

Your new Trumpet includes these accessories.

1. Polishing Cloth
2. Valve Oil



## 3. THIS IS WHAT YOUR TRUMPET WILL LOOK LIKE WHEN ASSEMBLED

This picture shows you what your Trumpet will look like when it has been completely assembled. Read the next sections to learn how to put your Trumpet together so that it looks like this when you are finished.

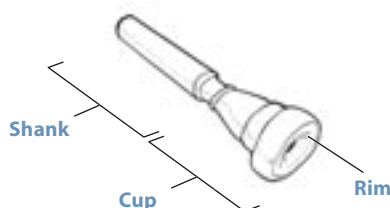
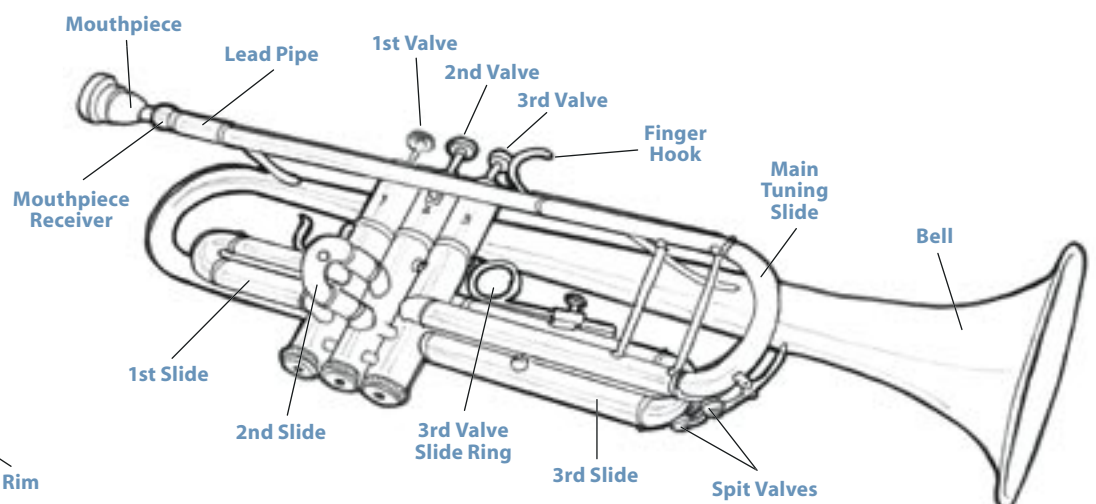

## 4. HOW TO PUT YOUR NEW TRUMPET TOGETHER

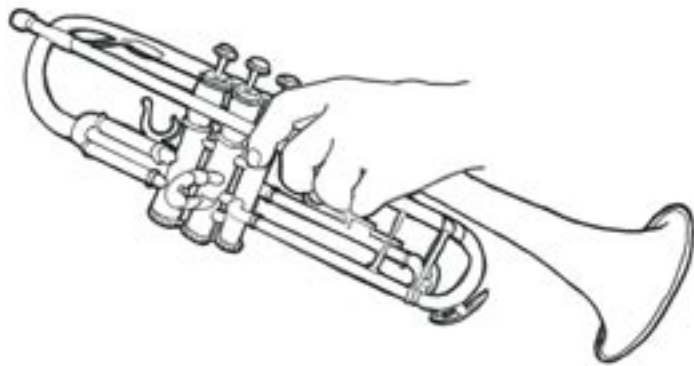

### A. How to Hold Your Trumpet

- Locate the Trumpet in the case.
- Carefully remove the Trumpet from the case and hold it as shown.

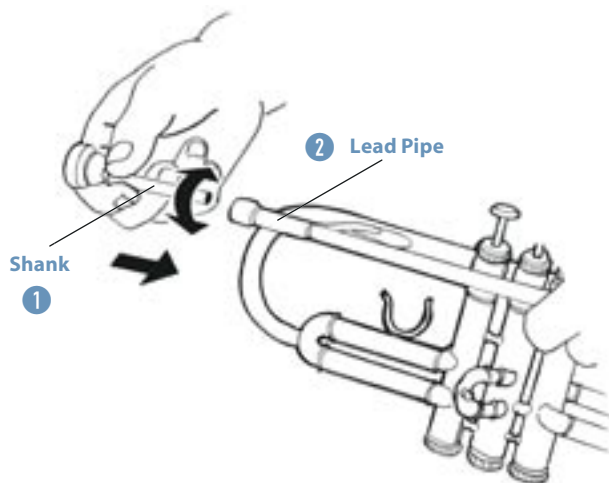

### B. Put on the Mouthpiece

- To insert the Mouthpiece, take the long thin end, called the Shank, and place it into the Lead Pipe end of the Trumpet. ①
- Gently twist the Mouthpiece into the Lead Pipe. ②

#### BE CAREFUL!

*The Lead Pipe is very delicate. Do not hit or bend it. Do not push the Mouthpiece into the Lead Pipe too much or tap on the Mouthpiece as it may get stuck.*

### C. Trumpet Playing Positions

- This is the correct position of your Right Hand. ①
- This is the correct position of your Left Hand. ②

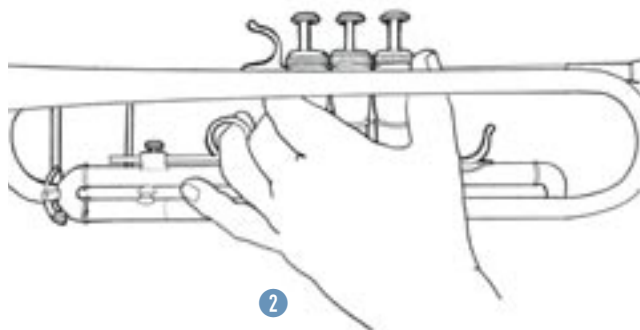
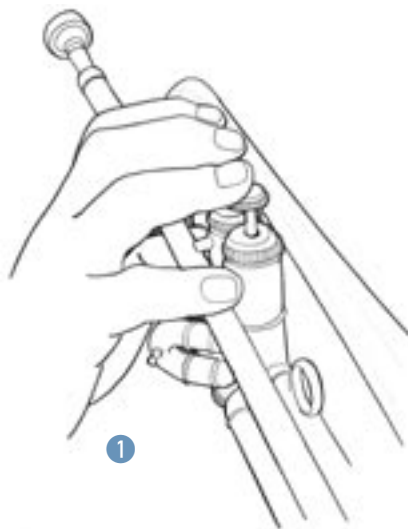

**Your new Trumpet should now look like this. *Have fun!***



## 5. GOOD TIPS ON PLAYING THE TRUMPET

- Keep good posture at all times. Sit or stand straight and centered.
- Take in full amounts of air.
- Don't breath air out but blow air out through the Trumpet.
- Keep lips moist and slightly stretched so that the front of the lips has a small opening.
- Learn to blow a steady stream of air with only slight pressure on the lips.
- Keep the mouthpiece in the center of your lips.
- Keep your cheeks flat.
- Keep the tongue relaxed with the tip resting behind the bottom teeth.
- Warm-up on the Mouthpiece whenever you can, keeping different vowels in mind, like eeee, ahhh, and ooo. Try buzzing these vowels even changing from one to another like a fire siren.
- Try to keep your chin down and keep the corners of your mouth firm. Occasionally practice in front of a mirror.
- The higher the notes the more you should feel that you are blowing down into the Mouthpiece.
- Air must move quickly through a small opening in the lips for the best sound.
- This Trumpet comes with a #7C Mouthpiece. This is the most common size.

## 6. WHEN YOU HAVE FINISHED PLAYING YOUR TRUMPET

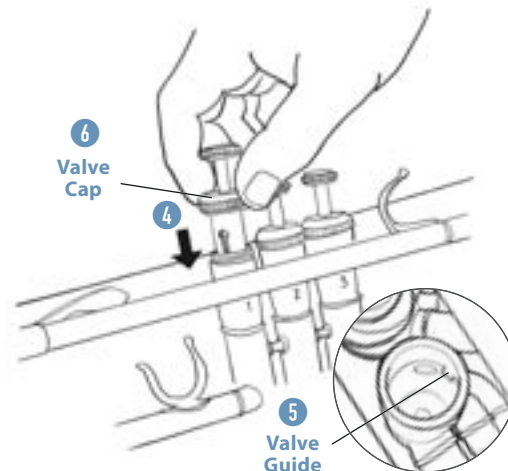
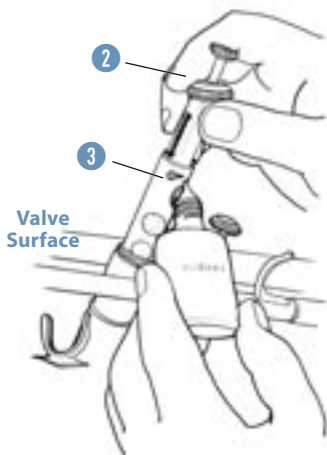
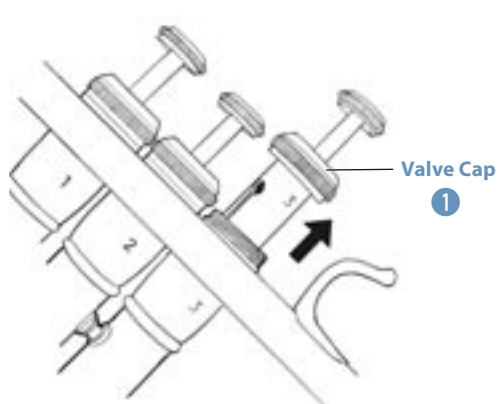

### A. How to Oil the Valves

- The Valves should be oiled once every week or two. Carefully unscrew the Valve Cap. ①
- Lift out the Valve Cap and Valve. ②
- Apply only a few drops of Valve Oil on the Valve surface. ③

**BE CAREFUL!** *There is a number on each Valve and Valve Casing. Be Careful when putting the Valves back, make sure the Valve numbers match.*

*Do not remove all the Valves at the same time. Remove and Oil one Valve at a time.*

*Do NOT force the Valve back into the Valve Casing. Use a slow, gentle back and forth motion as you lower the Valve into the Valve Casing*

- Return the Valve back to the SAME Valve casing it came from.
- Slowly and gently push the Valve back into the top of the Valve Casing. ④
- The Valve MUST line up with a Valve Guide INSIDE the Valve Casing. ⑤
- As you lower the Valve, twist it back and forth until it locks into place.
- When it is in all the way down, tighten the Valve Cap. ⑥

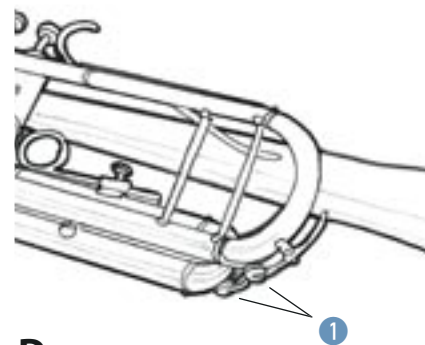
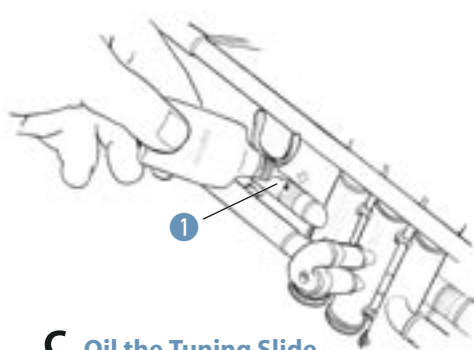
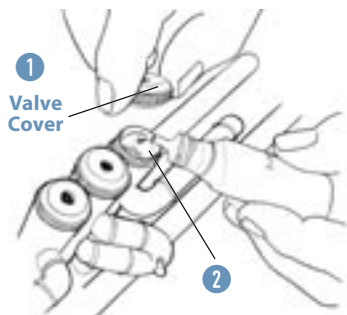

### B. Oil the Valve Cover

- Turn your Trumpet upside down.
- Unscrew the bottom Valve Cover. ①
- Place only a couple drops of Valve Oil onto the Valve Casing as shown. ②
- Repeat for each Valve.

### C. Oil the Tuning Slide

- Locate the Tuning Slide on your Trumpet. ①
- Pull the Tuning Slide out a few inches.
- Place only a couple drops of Valve Oil onto the Tuning Slide as shown.

### D. Spit Valves

- Frequently use the two Spit Valves to remove condensation from the Trumpet. ①

**BE CAREFUL!**

*Make sure to place the trumpet back in its compartment carefully.*

*Don't force the lid down.*

*Close the top on the Valve Oil Bottle securely to prevent leaks.*

# Care & Maintenance

## DO'S

## DON'TS

- DO** Be careful when handling your Trumpet. It is a delicate instrument.
- DO** Wipe off the Trumpet and Mouthpiece after you have finished playing.
- DO** Carefully place the Trumpet and Mouthpiece back in the correct compartment in the Case.
- DO** Oil the Valves every few weeks.
- DO** Use a gentle twisting motion when putting on the Mouthpiece.
- DO** Use the 2 Spit Valves after each playing session.

- DON'T** Force the sections into the Case.
- DON'T** Close the lid if it seems difficult.
- DON'T** Eat while playing.
- DON'T** Force the Mouthpiece into the Lead Pipe.
- DON'T** Hit the Lead Pipe. It is very delicate..
- DON'T** Don't remove all 3 valves at the same time.



CONCERTINO COLLECTION  
*Trumpet*  
INSTRUMENTS THAT OUTPERFORM



The Name You Know

[www.suzukibandinstruments.com](http://www.suzukibandinstruments.com)